

INTEGRA



EVOLVE Manual Pipettes

Operating Instructions

INTEGRA Declaration of Conformity

INTEGRA Biosciences Corp. – Hudson, NH, USA

declares on its own responsibility that the devices

Description	Models
EVOLVE Manual Pipettes	3011, 3012, 3013, 3015, 3016, 3018, 3019, 3022, 3024, 3025, 3026, 3028, 3032, 3034, 3035, 3036, 3038, 3042, 3044, 3045

comply with:

EU Regulations	Scope	Date effective
1907/2006	Registration, evaluation, authorisation and restriction of chemicals (REACH)	01.06.2007

EU Standards	Scope
EN 9001:2015	Quality Management

USA Regulations	Scope
17 CFR Parts 240 & 249b	Dodd frank "Conflict minerals"
27 CCR Parts 25102-27001	Proposition 65: The safe drinking water and toxic enforcement act
TSCA 40 CFR Part 751	Toxic substances control act

International Standards	
ISO 8655-2	Piston pipettes

Zizers, 2023-12-08

Urs Hartmann
CEO

Daniela Gross
Head of Corporate Quality

Table of Contents

Chapter 1	Introduction	
	1.1 Symbols used	5
	1.2 Intended use	5
	1.3 Safety notes	6
Chapter 2	Description of the device	
	2.1 Scope of delivery	7
	2.2 Overview of the EVOLVE manual pipettes	7
Chapter 3	Operation	
	3.1 Setting the volume	8
	3.2 Attaching and removing GRIPTIP pipette tips	8
	3.3 Pipetting	9
	3.3.1 Aspirating and dispensing	9
	3.3.2 Reverse mode	10
	3.3.3 Proper pipetting techniques	11
	3.4 Troubleshooting	12
Chapter 4	Maintenance	
	4.1 Cleaning	13
	4.2 Single channel lower end disassembly	13
	4.2.1 Disassembly	13
	4.2.2 Reassembly	17
	4.3 Sterilization	19
	4.3.1 Autoclaving the disassembled components	19
	4.4 Servicing	20
	4.4.1 Shipping to INTEGRA Biosciences	20
	4.4.2 Changing O-rings of tip fittings	20
	4.4.3 Lubrication	21
	4.5 Calibration	22
	4.5.1 Materials	22
	4.5.2 Definitions	22
	4.5.3 Test conditions and environment	23
	4.5.4 Pre-wetting of tips	23
	4.5.5 Leak test	24
	4.5.6 Obtaining the actual volume	25
	4.5.7 Calculation of accuracy and precision	26
	4.5.8 Adjusting EVOLVE manual pipettes	27
	4.6 Equipment disposal	28

Chapter 5 Technical data

5.1 Environmental conditions 29
5.2 Pipette specifications 30
5.3 Z correction factors 32

Chapter 6 Accessories and Consumables

6.1 Accessories 33
6.2 Consumables 33
6.3 GRIPTIPS 34
 6.3.1 GRIPTIPS for handheld pipettes 34
 6.3.2 Package options 34
 6.3.3 GRIPTIP properties 34

Imprint 35

1 Introduction

These operating instructions contain all the information required for installation, operation and maintenance of the EVOLVE manual pipettes. This chapter informs about the symbols used in these operating instructions, the intended use of the EVOLVE manual pipettes and the general safety instructions.

1.1 Symbols used

The operating instructions specifically advise of residual risks with the following symbols:

**WARNING**

This safety symbol warns against hazards that could result in injury. It also indicates hazards for machinery, materials and the environment. It is essential that you follow the corresponding precautions.

**CAUTION**

This symbol cautions against potential material damage. Follow the instructions.

**NOTE**

This symbol identifies important notes regarding the correct operation of the device and labor-saving features.

1.2 Intended use

This is a general-purpose laboratory instrument for use in research only. Any use of this instrument in a medical or IVD setting is under the sole responsibility of the user.

EVOLVE manual pipettes are intended to be used in a laboratory for aspirating and dispensing liquids in the volume range of 0.2–5000 µl using GRIPTIP pipette tips.

1.3 Safety notes

EVOLVE manual pipettes comply to the recognized safety regulations and is safe to operate. EVOLVE manual pipettes can only be operated when in perfect condition and while observing these operating instructions.

The device may be associated with residual risks if it is used or operated improperly by untrained personnel. Any person operating the EVOLVE manual pipettes must have read and understood these operating instructions, and particularly, the safety notes, or must have been instructed by supervisors so that safe operation of the device is guaranteed.

**WARNING**

When handling dangerous substances, comply with the material safety data sheet (MSDS) and with all safety guidelines such as the use of protective clothing and safety goggles.

Only use GRIPTIPS® brand pipette tips to ensure the proper function of the EVOLVE manual pipettes and to comply with the general warranty conditions. Damage to the pipettes and risk to operator's health and safety may result from using non-specified pipette tips.

**CAUTION**

- *Do not immerse the EVOLVE manual pipettes in liquid. The fluid can damage internal parts. Avoid pipetting of liquids whose vapors could attack the materials PA (polyamide), POM (polyoxymethylene), FPM (fluor-rubber), NBR (nitrile-rubber), CR (chloroprene), silicone. Corrosive vapors could also damage metallic parts inside the device.*
- *Repairs may only be performed by INTEGRA Biosciences AG or by an authorized after-sales service member.*
- *Parts may be replaced with original INTEGRA Biosciences parts only.*

**NOTE**

Prolonged exposure of the EVOLVE manual pipettes to UV-light can cause discoloration and/or yellowing of the pipette housing. However, this will not affect the performance of the device in any way.

Regardless of the listed safety notes, additional applicable regulations and guidelines of trade associations, health authorities, trade supervisory offices, etc. must be observed.

Please visit our website www.integra-biosciences.com on a regular basis for up to date information regarding REACH classified chemicals contained in our products.

2 Description of the device

2.1 Scope of delivery

- EVOLVE manual pipette
- Multipurpose tool
- Color coded plunger cap
- Quick start guide
- Replacement O-rings (for 200 µl, 1000 µl and 5000 µl models)

2.2 Overview of the EVOLVE manual pipettes

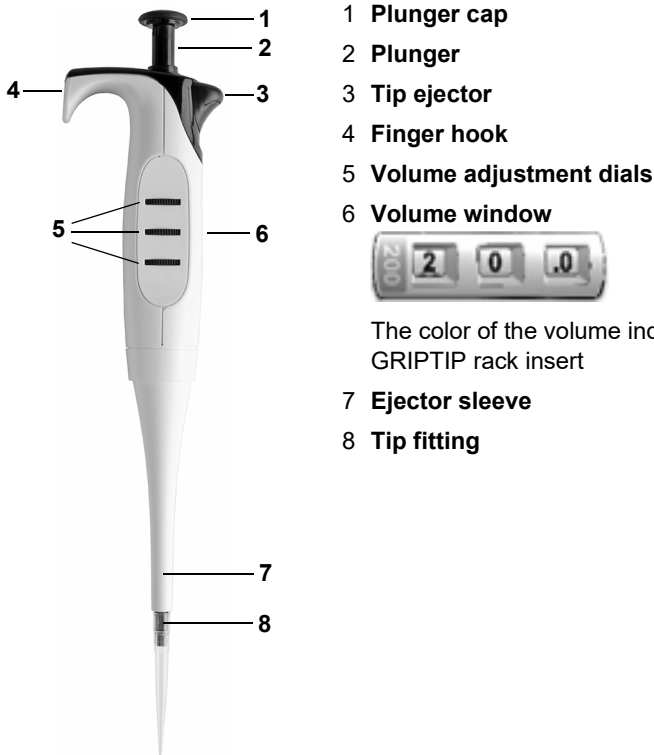

3 Operation

3.1 Setting the volume

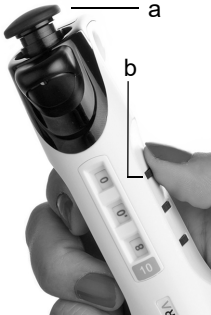

- 1) To set the desired pipetting volume press down the **plunger** (a) and rotate slightly clockwise to release the volume dials.
- 2) Spin the **adjustment dials** (b) until the desired volume is shown in the volume window.
- 3) Slightly rotate and slowly release the **plunger** (a) to set the volume.

3.2 Attaching and removing GRIPTIP pipette tips



CAUTION

To ensure optimal performance of your EVOLVE manual pipettes always use GRIPTIPS of correct size which have been designated for the use with the EVOLVE manual pipettes, see [“6.2 Consumables” on page 33](#).

The unique GRIPTIP system of the EVOLVE manual pipettes reduces attachment and ejection forces, ensures a perfect fitting to prevent the tips from falling off and provides a perfect seal. On a multichannel pipette, all tips sit at the same height.



A rim inside the GRIPTIPS snaps over the multi-lobes and ensures firm attachment of the tips.

A shoulder provides a positive stop to prevent over-tightening of the tips. Without hammering, the tip is either on or off but nothing in between.

O-ring provides forgiving and robust seal surface for the pipette tip.

Attach the tips:

When loading tip(s), press the pipette into the appropriate GRIPTIP(s) until you hear and feel a click indicating that a seal has been achieved. Once you feel the click, stop applying pressure. When loading GRIPTIP pipette tips using a multichannel pipette, slowly rock the pipette from one side to the other side to ensure the proper seal is achieved.

Discard your used tips:

If liquid is in the tips, empty them by pressing down the **plunger** (2) to the second stop (see section [3.3](#)). Tips are easily removed by pressing the **tip ejector** (3).

3.3 Pipetting

The plunger can be pushed down to two different stops:

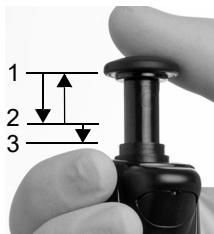

- 1) Top position: Varies depending on volume setting.
- 2) First stop: Fixed calibrated position for aspirating and dispensing.
- 3) Second Stop: To blowout the residual liquid.

For detailed recommendations for pipetting, see also [“3.3.3 Proper pipetting techniques”](#) on page 11.

3.3.1 Aspirating and dispensing

To aspirate and dispense liquid, perform the following steps:

Aspirate

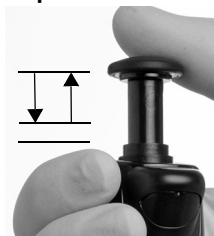

- 1) With GRIPTIPS attached, push down the **plunger** to the first stop.
- 2) Immerse the GRIPTIPS in liquid.
- 3) Slowly return **plunger** to the top position. For higher volumes (>200 µl), follow the liquid level by moving the pipette down.
- 4) Remove the GRIPTIPS from liquid.

Dispense



- 5) To dispense the liquid, push the **plunger** down to the first stop.
- 6) If there is any residual liquid in tip, a blowout should be performed by pressing the **plunger** to the second stop.
- 7) Remove the GRIPTIPS from vessel and release **plunger**.

3.3.2 Reverse mode

Viscous samples should be aspirated and dispensed at slower speeds and in reverse pipetting mode:

Aspirate

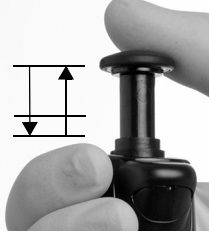

- 1) Fully push down the **plunger** to the second stop.
- 2) Immerse the GRIPTIPS in the liquid, let the **plunger** slowly release to the upper position and wait shortly until the liquid is fully aspirated.

Dispense

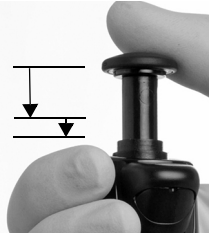

- 3) To dispense, press the **plunger** slowly down to the first stop and wait a few seconds to dispense the liquid.
- 4) Remove the GRIPTIPS from the target vessel.
- 5) To expel the excess liquid, press the **plunger** to the second stop.

3.3.3 Proper pipetting techniques

INTEGRA Biosciences recommends the following techniques for enhancing pipetting results. These techniques are consistent with ISO standard 8655-2.

- It is best to immerse the GRIPTIPS just below the surface of the liquid (2–3 mm) to allow the desired volume to be aspirated. If the tip is immersed too deep, the risk of carry-over is increased due to liquid drops clinging to the outer surface of the tip.
- Press and release the plunger with consistent speed and smoothness.
- Always pre-wet GRIPTIPS. After loading tips onto your pipette, aspirate and dispense the full volume 2-3 times to coat the inside of pipet tips. Pre-wetting ensures that the liquid and air inside the tips are at equal temperature and the dead air space is humidified. Neglecting to perform a pre-wet can result in a smaller delivery volume in the first few dispenses.
- EVOLVE manual pipettes are air displacement pipettes. To properly dispense liquids, ensure that the pipette tip is at a 0–20° angle. After each dispense, you must touch GRIPTIPS against the vessel wall or liquid. This process is referred to as “touching off” or “tip touch” and prevents liquid from clinging to the pipette tips.
- Air displacement pipettes show the best performance between 35% and 100% of the nominal volume.
- Viscous samples should be aspirated and dispensed at slow speeds to ensure accurate pipetting. In addition, pipetting should be performed in a reverse mode.
- For pipetting liquids with high vapor pressures (such as methanol or ethanol), use relatively fast pipetting speeds and avoid prolonged pauses after aspiration.
- Calibrate based on fluid type. EVOLVE manual pipettes are tested and calibrated at the factory for use with distilled water at room temperature. It may be necessary to re-calibrate your EVOLVE manual pipettes if the liquid to be used has different physical properties (specific gravity and vapor pressure) than water.



WARNING

Avoid pipetting for extended periods. To minimize the risk of repetitive strain injury, include pauses of several minutes.

Use filtered GRIPTIPS to pipette corrosive or biohazardous liquids. The filter prevents vapors and aerosols from corroding or contaminating the cylinder assembly.

3.4 Troubleshooting

Problem	Probable cause	Remedy
Leaking.	<ul style="list-style-type: none"> • Tip incorrectly attached. • Foreign particles between tip and tip fitting. • Damaged colored O-ring. 	<ul style="list-style-type: none"> • Attach a new tip. • Clean tip fitting. Attach new tips • Change the O-ring, see 4.4.2. • If leak persists, contact service.
Dispense results are inaccurate.	<ul style="list-style-type: none"> • Unsuitable calibration for liquid class. • Improper pipetting techniques. 	<ul style="list-style-type: none"> • Recalibrate with the liquids in question. • Adjust aspiration and dispense speed depending on liquid: <ul style="list-style-type: none"> - High viscosity liquids may require calibration. - High vapor pressure liquids may require pre-wetting. - Refer to proper pipetting techniques section 3.3.3
Not dispensing/aspirating.	<ul style="list-style-type: none"> • Piston stuck or not connected. • Internal seal is damaged. 	<ul style="list-style-type: none"> • Contact service.
Droplets on the tips.	<ul style="list-style-type: none"> • Temperature of liquid differs from that of air inside the tips. • Liquid of low viscosity and high vapor pressure. • Touch off was not performed. 	<ul style="list-style-type: none"> • Pre-wet tips up to 3 times. • Increase dispensing speed. • Perform a touch-off.

4 Maintenance

4.1 Cleaning

The materials used on the exterior of the EVOLVE manual pipettes support regular cleaning intervals. Clean the external components with a lint-free cloth lightly soaked with mild soap solution in distilled water or with a 70 % dilution of Isopropyl or Ethanol. Never use acetone or other solvents.

**WARNING**

- *DO NOT immerse the entire pipette into the cleaning solution.*
- *DO NOT spray cleaning solution directly onto the exterior body of the pipette.*

If the pipette is exposed to corrosive vapors, e.g. from concentrated acids, or if liquid enters the lower pipetting end, disassemble the lower part of the pipette and clean the internal parts with distilled water or with a 70 % dilution of Isopropyl or Ethanol. Follow the instructions below for disassembly.

4.2 Single channel lower end disassembly

4.2.1 Disassembly

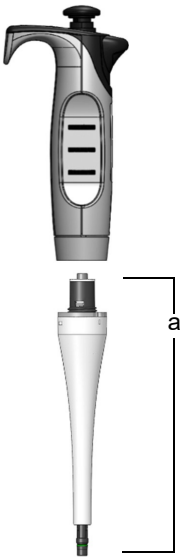
**Models of all sizes:**

- 1) Before you separate the lower part from a single channel pipette, press down the plunger.
- 2) Unscrew the **cylinder assembly** (a) clockwise and gently remove it from the pipette body.

Models 2–1000 µl:

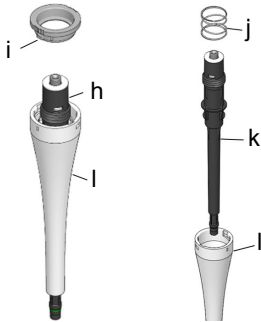

2–1000 µl

Models 2–1000 µl:

- 3) With the **cylinder assembly** (a) in a hand, turn counterclockwise to remove the **snap ring** (i). Pull out black **cylinder** (k) from white **sleeve** (l). Remove the **ejector spring** (j).

Set the **snap ring** (i), **sleeve** (l) and **ejector spring** (j) aside or place them in an autoclave pouch.

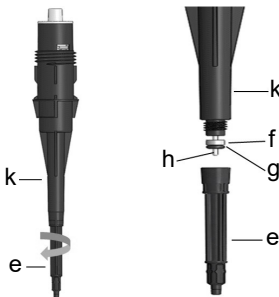

2 and 10 µl

Models 2 and 10 µl:

- 4) Unscrew **tip fitting** (e) from the **cylinder body** (k). Slide the **O-ring** (g) and the white **seal** (f) from the **piston** (h). If these parts are still stuck in the **tip fitting** (e), tap the top face of the tip fitting on the table.

Set these components aside or place them in an autoclave pouch.

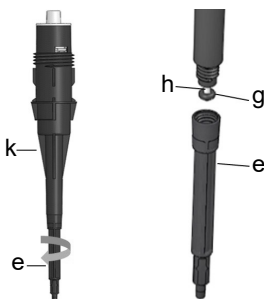

20 and 100 µl

Models 20 µl and 100 µl:

- 4) Unscrew **tip fitting** (e) from the **cylinder body** (k). Slide the **O-ring** (g) from the **piston** (h). If the **O-ring** (g) is still stuck in the **tip fitting** (e) after it has been removed, tap the top face of the **tip fitting** on the table.

Set these components aside or place them in an autoclave pouch.

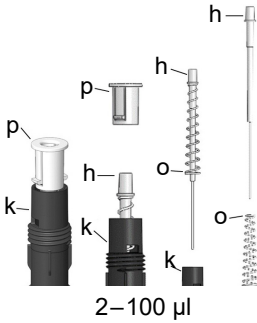

Models 2 –100 µl:

- Remove **self-containment cap** (p) from the **cylinder body** (k).
Pull out **piston** (h) from the **cylinder body** (k).
Remove the **compression spring** (o) from the **piston** (d).

Set these components aside or place them in an autoclave pouch.

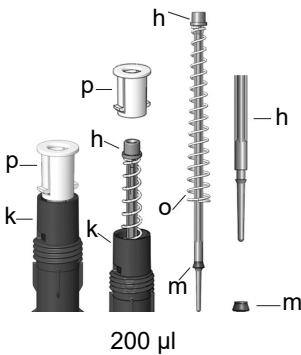

Model 200 µl:

- Remove **self-containment cap** (p) from the **cylinder body** (k).
Pull out **piston** (h) from the **cylinder body** (k).
Remove the **compression spring** (o) from the **piston** (h).

Set these components aside or place them in an autoclave pouch.

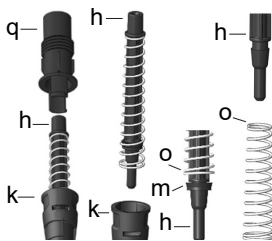

Model 1000 µl:

- Remove **cylinder adapter** (q) from the **cylinder body** (k).
Pull out **piston** (h) from the **cylinder body** (k).
Compress the **compression spring** (o) with one hand, then remove the **cup seal** (m) from **piston** (h).
Remove the **compression spring** (o) from the **piston** (h).

Set these components aside or place them in an autoclave pouch.



1000 µl

Model 5000 µl:

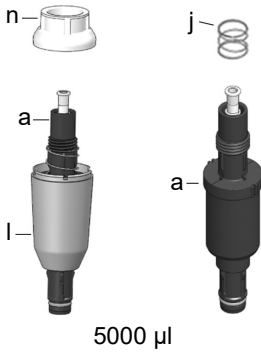

Model 5000 µl:

3) Remove white **sleeve cap** (n) from white **ejector sleeve** (l).

Pull out **cylinder assembly** (a) from **ejector sleeve** (l).

Pull out **ejector spring** (j) from **cylinder assembly** (a).

Set the **sleeve cap** (n), **ejector sleeve** (l) and **ejector spring** (j) aside or place them in an autoclave pouch.

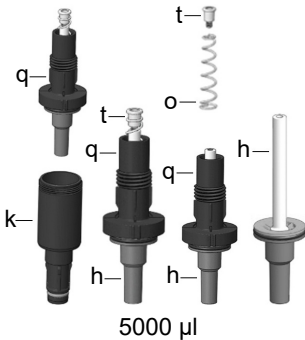

Model 5000 µl:

4) Unscrew the **cylinder adapter** (q) from the **cylinder body** (k).

Unscrew the **piston head** (t) from **piston assembly** (h).

Remove **compression spring** (o) from **piston** (h).

Remove **cylinder adapter** (q) from **piston** (h).

Set these components aside or place them in an autoclave pouch.

4.2.2 Reassembly

Before reassembling the pipette, check each component for lint or dust particles. It is recommended to replace the **O-ring** and **seal** or **cup seal**. Lightly lubricate the piston, O-rings and seals (see [“4.4.3 Lubrication”](#) on page 21).

Models 2 µl– 100 µl:

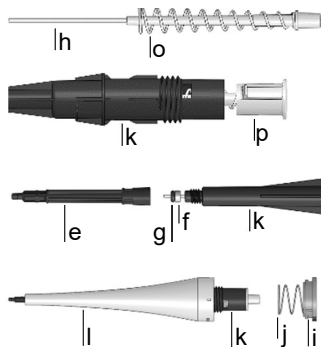

- 1) Slide the **compression spring** (o) into the **piston** (h).

Place **piston** (h) into **cylinder** (k). Press the **self-containment cap** (p) into the **cylinder** (k), and make sure it aligns with notches on **cylinder** (k).

- 2) Slide the **seal** [(f); 2-10 µl only] and **O-ring** (g) into the **piston** (h) and lightly lubricate.

Screw **tip fitting** (e) into **cylinder body** (k).

- 3) Place the **cylinder** (k) inside the white **sleeve** (l). Place the **ejector spring** (j) over the **cylinder** (k). Place the **snap ring** (i) on the white **sleeve** (l). Turn the **sleeve** (l) clockwise until the **snap ring** (i) snaps into place and secures the **cylinder** in the **cylinder assembly**.

Model 200 µl:

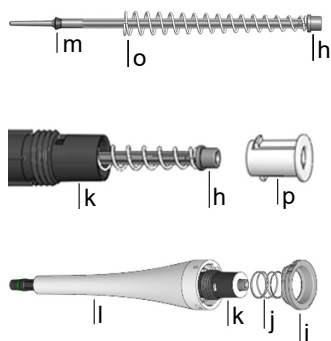

- 1) Slide the **cup seal** (m), and the **compression spring** (o) into the **piston** (h), lightly lubricate **cup seal** (m). Be sure the **compression spring** (o) is placed into the **piston** (h) with the small end first.

- 2) Place the **piston** (h) inside the **cylinder** (k), and place **self-contained cap** (p) into the **cylinder**. Make sure **self-contained cap** (p) aligns with notches on **cylinder**.

- 3) Slide the **cylinder** (k) into the white **sleeve** (l). Place the **ejector spring** (j) over **cylinder**. Place **snap ring** (i) on the white **sleeve** (l). Turn the **sleeve** clockwise until the **snap ring** (i) snaps into place.

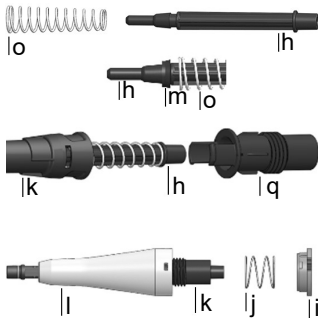
Model 1000 µl:

- 1) Slide **compression spring** (o) into the **piston** (h). While compressing the **spring** (o) back, insert **cup seal** (m) into the **piston** (h) and lightly lubricate.
- 2) Insert the **piston** (h) into the **cylinder** (k). Place **cylinder adapter** (q) into the **cylinder** (k). Make sure **cylinder adapter** (q) aligns with the pair of slots on **cylinder**.
- 3) Place **cylinder** (k) inside white **sleeve** (l). Place **ejector spring** (j) over cylinder. Place **snap ring** (i) on the white **sleeve** (l). Turn the **sleeve** clockwise until the **snap ring** (i) snaps into place.

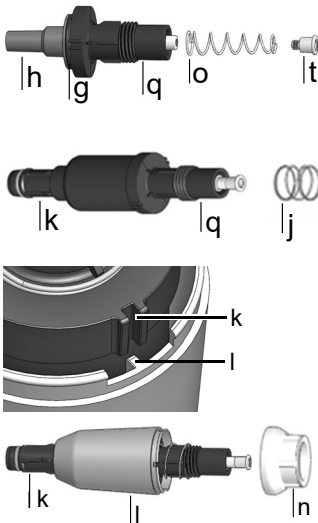
Model 5000 µl:

- 1) Place the **cylinder adapter** (q) over the **piston rod** (h). Slide the **compression spring** (o) into the **piston** (h). Screw **piston head** (t) into piston to secure the **compression spring** (o) and **cylinder adapter** (q). Lightly lubricate **O-ring** (g).
- 2) Screw the **piston assembly** (h) to the **cylinder** (k). Slide the **ejector spring** (j) on the **cylinder adapter** (q).
- 3) Place the **cylinder** (k) inside the white **sleeve** (l). Ensure to align the slots on the **cylinder** (k) with the bosses inside the **sleeve** (l).
- 4) Re-attach the **sleeve cap** (n) to the white **sleeve** (l). Ensure that the **sleeve cap** (n) aligns to the openings of the **sleeve** (l).

Models of all sizes:

- 5) Position the **piston** to the **piston drive plug** to connect the piston to the upper part of the pipette.
- 6) Screw the **cylinder assembly** (a) counterclockwise to attach it to the body of the pipette.

Perform a leak test (see [“4.5.5 Leak test”](#) on page 24) and validate pipetting volumes after reassembly.

4.3 Sterilization

If the surface of the EVOLVE manual pipettes have been in contact with biohazardous material, they must be decontaminated in accordance to good laboratory practice. Wipe the clean surface with a lint-free cloth, lightly soaked e. g. with the following disinfectants:

- Ethanol 70 %
- Microcide SQ 1:64
- Glutaraldehyde solution 4 %
- Virkon solution 1-3%

Follow the instructions provided with the disinfectants.

The device may be decontaminated with H₂O₂ gas (maximal concentration 35 %) for 60 minutes.

It is not recommended to autoclave the EVOLVE manual pipettes. If autoclaving is required, only the lower assembly of the EVOLVE single channel pipettes can be autoclaved.



WARNING

Service is required after autoclaving the EVOLVE manual pipettes!

Do not autoclave the entire unit. Multichannel pipettes CANNOT be autoclaved, they might be damaged!

As-found calibration (measurement report, indicating “before” data) is not possible after autoclaving!

4.3.1 Autoclaving the disassembled components

Place the disassembled components (see [4.2.1](#)) into steam autoclave in an autoclave pouch.

You may autoclave the components at 121°C, 1 bar overpressure for 20 minutes.



CAUTION

Service is required after autoclaving the EVOLVE Manual Pipettes!

4.4 Servicing

4.4.1 Shipping to INTEGRA Biosciences

For any service or repairs, please contact your local service technician.

**WARNING**

If working with infectious materials, e. g. human pathogens, the EVOLVE manual pipettes need to be decontaminated before sending to service and the declaration on the absence of health hazards must be signed. This is necessary to protect service personnel.

4.4.2 Changing O-rings of tip fittings

200 µl, 1000 µl and 5000 µl EVOLVE manual pipettes feature tip fittings with colored O-rings. This O-ring is used to seal against the inside wall of GRIPTIPS and provides a robust seal.

O-rings are made of durable silicone. If necessary, e.g. in case of a leakage due to damaged O-ring, you can replace these O-rings. A set of spare O-rings can be ordered separately, see [“6.2 Consumables”](#) on page 33.

**WARNING**

Avoid mechanical damage of the tip fittings.

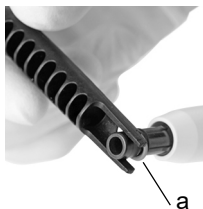

For 200 µl or 1000 µl pipettes, slide the multipurpose tool sideways onto the tip fitting until the O-ring (a) builds a loop. Remove the O-ring with plastic tweezers.

For 5000 µl pipettes, simply use plastic tweezers to remove the O-ring.

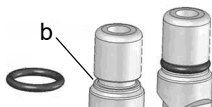

Slide a new O-ring over the tip fitting (b).

4.4.3 Lubrication

The internal seals and O-rings are subject to wear. An undamaged thin lubricant film is important to keep the seals tight. The lubricant recommended depends on the EVOLVE pipette size, see “6.2 Consumables” on page 33:



Single channel 2 µl – 10 µl models:

Use the Klüberalfa lube (#500-00182-00) to lightly lubricate the piston (h). Lightly lubricate outer ring of the **O-ring** (g) and the **white seal** (f).



Single channel 20 µl and 100 µl model:

Use the Klüberalfa Lube (#500-00182-00) to lightly lubricate the **piston** (h). Lightly lubricate the outer ring of the **O-ring** (g).

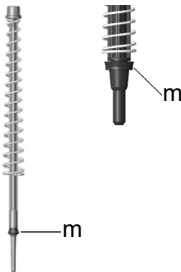

Single channel 200 µl and 1000 µl models:

Use the Klüberalfa lube (#500-00182-00) to lightly lubricate the outer ring of the **cup seal** (m). Do not lubricate the bottom of **cup seal**.

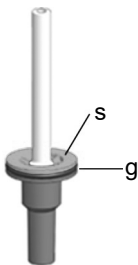

Single channel 5000 µl model:

Use the Klüberalfa Lube (#500-00182-00) to lightly lubricate the outer ring of the **compression cap** (s) and **O-ring** (g). Do not lubricate the bottom of **compression cap** (s).

4.5 Calibration

The EVOLVE manual pipettes are factory tested and calibrated under environmentally controlled conditions using a gravimetric procedure in accordance with ISO 8655 standards. For the accuracy and precision specifications, see [“5.2 Pipette specifications” on page 30](#).

For information regarding calibration service, please contact your local dealer.

4.5.1 Materials

- Precision balance with 0.01 mg readability
- ASTM Class 2 or OIML E2 test weights
- Evaporation trap for balance
- Weighing vessel (optimally the height-to-diameter ratio is at least 3:1)
- Measurement equipment for temperature, humidity and atmospheric pressure
- Distilled water (Grade 3 according to ISO 3696)
- New non-filtered GRIPTIPS matching the pipette volume (see section [6.2](#))
- 1 beaker with distilled water

4.5.2 Definitions

Blow-out: Discharges any residual liquid from the pipette tip.

Blow-in: After the blow-out, the piston moves back into home position. This causes a slight intake of air (or liquid if tips remain in the liquid).

Two step blow-out: To avoid an early blow-in, keep the plunger pressed after dispensing, remove the tips from liquid and then release the plunger.

Pre-wet: The action of pre-coating the inside of the liquid contacting parts with a thin film of the same liquid. Additionally, it equilibrates humidity of the air space inside tip and the pipette.

Touch off: Touching the pipette tip against the surface liquid or side of well-plate to release any sample liquids that might be on the end of the pipette tip.

4.5.3 Test conditions and environment

Tests and calibrations should be performed in conditions and environment according to ISO 8655-6 standard.

- Temperature needs to be between 18–25 °C and remain constant (± 0.5 °C) throughout the calibration.
- Optimal relative humidity of the environment is >50% and around the dispensing position 80%.
- GRIPTIPS, pipettes and distilled water need to be in the calibration laboratory for at least 2 hours prior to calibration to reach temperature equilibrium with the environment.
- The balance must be validated using reference weights before and after a measuring series. A low and high volume weight should be used. E.g.:
 - 100 g (Mettler Toledo, #11119250)
 - 10 g (Mettler Toledo, #11119220)
 - 1 g (Mettler Toledo, #11119190)
 - 10 mg (Mettler Toledo, #11119130)



CAUTION

Always use new, pre-wetted GRIPTIPS for leak test and calibration.

4.5.4 Pre-wetting of tips

Pre-wet new GRIPTIPS three times prior to starting tests and calibrations. This is required every time a tip is changed.

- 1) Set the pipette to aspirate full volume.
- 2) Attach a new unused GRIPTIP which correspond to the volume range of the pipette directly from the rack without touching the tip by hand.
- 3) Use a separate waste container for pre-wet dispenses.
- 4) Push down the plunger to the first stop. Aspirate by releasing with medium speed.
- 5) Dispense: Keep the plunger pressed to the first stop until all liquid is expelled.

At the end of the third cycle push the plunger to the second stop, remove the tip from the liquid and then release the plunger to perform a two-step blowout.

4.5.5 Leak test

It is recommended to perform a leak test every 3 months or when errors occur.

- 1) Prewet tips as described above.
- 2) Set the EVOLVE manual pipettes to aspirate full volume.
- 3) Push down the plunger to the first stop. Aspirate full volume by releasing with medium speed and verify liquid level is not decreasing during 10 seconds while GRIPTIPS are still in distilled water.
- 4) Remove the GRIPTIPS from the liquid and hold the pipette at a 20° angle. Wait for 20 seconds.
 - a) Observe whether liquid droplets are forming at the end of the GRIPTIPS.
 - b) On a multichannel pipette, verify liquid level is even across all channels.
- 5) Immerse GRIPTIPS approximately 2 mm into distilled water and push and release the plunger to mix six times.
 - a) Observe whether air bubbles are forming when dispensing.
 - b) On a multichannel pipette, check whether the levels stay approximately on the same level across all channels.
- 6) At the end push the plunger to the second stop and remove the tip from the liquid before releasing.

Signs indicating a leak

- 1) During the mix cycle in the leak test, the liquid level of 1 channel is decreasing.

**NOTE**

A decreasing liquid level at aspiration could be an indication of a slow leak. Performing a retest at 10 mixes may help identify a slow leak.

- 2) Liquid is left in a tip after the last dispense during the leak test.
- 3) One or more channels show air bubbles during the mix cycle in the leak test.
- 4) Droplets are forming when holding the pipette in the air for 20 seconds, even if a pre-wet was performed.
- 5) The liquid levels are not equal on all channels after aspiration.

If the pipette is leaking, change O-rings (see [4.4.2](#)) and lubricate pistons (see [4.4.3](#)) or contact your service technician.

4.5.6 Obtaining the actual volume

INTEGRA certifies the pipettes at 10% and 100% of the nominal value. For each volume 5 measurements are taken from all channels.

General

- 1) Always use new, unused GRIPTIPS, also when changing the test volume (e.g. from 200 μ l to 20 μ l).
- 2) Always pre-wet (section [4.5.4](#)) when using a new GRIPTIP. For a low volume measurement, first set the maximum volume for the pre-wet and then change to the volume to be measured.
- 3) After dispensing, perform a touch off to make sure no liquid remains on the tip.

Gravimetric testing

- 1) Write down the ambient temperature and air pressure.
- 2) Set the pipette to the high test volume.
- 3) Perform a pre-wet, see [4.5.4](#).
- 4) The first and second dispense to the balance should not be recorded. After each dispense re-tare the balance.
- 5) Aspirate the Target volume of water keeping the pipette in a vertical to 20-degree position while immersing the pipet tip 2–3 mm below the surface of the water. When withdrawing the tip from the liquid, gently wipe the tip against the side wall of the vessel to remove any liquid from the outside of the pipet tip.
- 6) Start the first measurement. Always pipet directly into the liquid of the weigh container on the balance. At the end push the plunger to the second stop and hold the plunger pressed until the pipette is removed from the weigh vessel to perform a 2-step blowout. Record the weight from the balance.
- 7) After completing the 5 high volume measurements, continue with the mid and low test measurements by repeating steps 3–6.

4.5.7 Calculation of accuracy and precision

Accuracy

The ability of a pipette to aspirate or dispense the exact volume desired. It indicates the proximity of measurement results to the true value. Accuracy is also known as systematic error and as the name indicates, can be corrected/calibrated.

Precision, coefficient of variation (CV)

Precision indicates the repeatability or reproducibility of the measurement. It is also called random error and is therefore an unpredictable error, which cannot be corrected/calibrated.

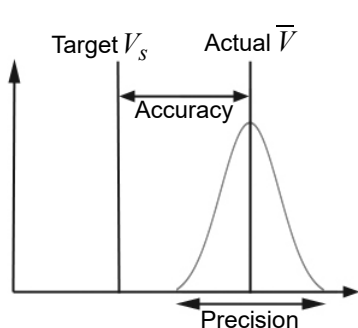

The following symbols are used throughout this text:

V_s = Selected test or target Volume

m_i = Measured Liquid Weight (g)

Z = Z factor, see [5.35.3](#)

V_i = Converted Volume (ml or μ l)

\bar{V} = Actual mean Volume (ml or μ l)

n = Number of measurements

Conversion of the mass to volume

The values obtained by balance readings are in grams. These values need to be converted to micro liters using the Z correction factor. It takes into account the water density and air buoyancy during weighing at the corresponding test temperature. To determine the correct Z factor, find the intersection between temperature and air pressure in [Table 5.35.3](#). Round up temperature and air pressure values.

Multiply each weight m_i obtained in [4.5.6](#) with the corresponding Z factor:

$$V_i = m_i \times Z$$

Add together the volumes V_i delivered, divide the sum by n (e.g. $n = 5$) to calculate the mean volume \bar{V} (in milliliters or micro liters) delivered at the test temperature, which is the Actual Volume:

$$\bar{V} = \frac{1}{n} \times \sum_{i=1}^n V_i$$

Calculation of systematic error (accuracy)

The systematic error e_s can be calculated using the following equation with V_s being the selected test volume:

$$e_s = \bar{V} - V_s$$

or in percent:

$$e_s = \frac{100 \times (\bar{V} - V_s)}{V_s}$$

Calculation of random error (precision %)

To calculate the random error as the repeatability standard deviation s_r , use the following equation:

$$s_r = \sqrt{\frac{\sum_{i=1}^n (V_i - \bar{V})^2}{n - 1}}$$

The random error can also be expressed as a percentage, by the coefficient of variation CV , using equation:

$$CV = 100 \times \frac{s_r}{\bar{V}}$$

If the pipette is properly calibrated, the Target volume V_s should equal the Actual volume \bar{V} within the accuracy specifications of the pipette.

4.5.8 Adjusting EVOLVE manual pipettes

Compare the calculated accuracy and precision values with the corresponding pipette specifications given in section [5.2](#).

The industry standard is to test and present specifications using neat transfers. This is aspirating and dispensing the same volume.

In case an EVOLVE Manual Pipette has not met the calibration specifications it needs to be adjusted. This can be corrected with the Multipurpose Tool.

Put the two teeth of the Multipurpose Tool into the slots on the top of the pipette.

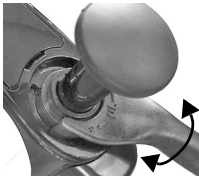

Rotate clockwise to increase the volume (slight turn up to a full turn).

Rotate counterclockwise to decrease the volume (slight turn up to a full turn).



NOTE

Validate the new volume set by repeating the gravimetric testing.

4.6 Equipment disposal



The EVOLVE manual pipettes must not be disposed of with unsorted municipal waste.



Dispose of the EVOLVE manual pipettes in accordance with the laws and regulations in your area.



In certain regions and countries, e.g. in EU member states, the distributor is obliged to take back this product free of charge at the end of life. Please contact your local distributor for more details.

5 Technical data

5.1 Environmental conditions

	Operation
Temperature range	5–40°C
Humidity range	Max. rel. humidity 80% for temperatures up to 31°C, decreasing linearly to 50% rel. humidity at 40°C.
Altitude range	<2000 m

5.2 Pipette specifications

The specifications apply only to neat transfers when the instrument is used together with INTEGRA GRIPTIPS and represent the performance of all channels on a multichannel pipette.

EVOLVE manual pipettes					Manufacturer	
Channel	Part No.	Volume range (µl)	Volume increments (µl)	Test volume (µl)	Accuracy (±%)	Precision (≤%)
1	3011	0.2–2	0.001	0.2	12.0	6.0
				1	3.0	1.6
				2	1.5	0.7
1	3012	1–10	0.01	1	5.0	1.5
				5	1.5	0.8
				10	1.2	0.5
1	3013	2–20	0.01	2	7.0	2.0
				10	1.6	0.5
				20	1.0	0.35
1	3015	10–100	0.1	10	3.5	1.0
				50	1.0	0.35
				100	0.8	0.2
1	3016	20–200	0.1	20	2.5	1.0
				100	1.0	0.3
				200	0.7	0.18
1	3018	100–1000	1	100	3.0	0.6
				500	1.0	0.3
				1000	0.8	0.2
1	3019	500–5000	5	500	3.0	0.6
				2500	1.2	0.3
				5000	0.6	0.18

EVOLVE manual pipettes					Manufacturer	
Channel	Part No.	Volume range (µl)	Volume increments (µl)	Test volume (µl)	Accuracy (±%)	Precision (≤%)
8	3022	1–10	0.01	1	12.0	7.0
				5	4.0	3.0
				10	2.0	1.2
8	3024	5–50	0.05	5	5.0	2.0
				25	2.0	1.0
				50	1.2	0.5
8	3025	10–100	0.1	10	5.0	1.5
				50	2.0	0.8
				100	1.2	0.3
8	3026	20–200	0.1	20	5.0	1.2
				100	2.0	0.5
				200	1.2	0.3
8	3028	100–1250	1.0	125	5.0	1.1
				625	1.8	0.7
				1250	1.0	0.3
12	3032	1–10	0.01	1	12.0	7.0
				5	4.0	3.0
				10	2.0	1.2
12	3034	5–50	0.05	5	5.0	2.0
				25	2.0	1.0
				50	1.2	0.5
12	3035	10–100	0.1	10	5.0	1.5
				50	2.0	0.8
				100	1.2	0.3
12	3036	20–200	0.1	20	5.0	1.2
				100	2.0	0.5
				200	1.2	0.3
12	3038	100–1250	1.0	125	5.0	1.1
				625	1.8	0.7
				1250	1.0	0.3

EVOLVE manual pipettes					Manufacturer	
Channel	Part No.	Volume range (µl)	Volume increments (µl)	Test volume (µl)	Accuracy (±%)	Precision (≤%)
16	3042	1–10	0.01	1	12.0	7.0
				5	4.0	3.0
				10	2.0	1.2
16	3044	5–50	0.05	5	5.0	2.0
				25	2.0	1.0
				50	1.2	0.5
16	3045	10–100	0.1	10	5.0	1.5
				50	2.0	0.8
				100	1.2	0.3

Precision = Coefficient of Variation.

5.3 Z correction factors

Temp. (°C)	Air pressure (kPa)						
	80	85	90	95	100	101.3	105
18.0	1.0022	1.0023	1.0023	1.0024	1.0025	1.0025	1.0025
18.5	1.0023	1.0024	1.0024	1.0025	1.0025	1.0026	1.0026
19.0	1.0024	1.0025	1.0025	1.0026	1.0026	1.0027	1.0027
19.5	1.0025	1.0026	1.0026	1.0027	1.0027	1.0028	1.0028
20.0	1.0026	1.0027	1.0027	1.0028	1.0028	1.0029	1.0029
20.5	1.0027	1.0028	1.0028	1.0029	1.0029	1.0030	1.0030
21.0	1.0028	1.0029	1.0029	1.0030	1.0031	1.0031	1.0031
21.5	1.0030	1.0030	1.0031	1.0031	1.0032	1.0032	1.0032
22.0	1.0031	1.0031	1.0032	1.0032	1.0033	1.0033	1.0033
22.5	1.0032	1.0032	1.0033	1.0033	1.0034	1.0034	1.0034
23.0	1.0033	1.0033	1.0034	1.0034	1.0035	1.0035	1.0036
23.5	1.0034	1.0035	1.0035	1.0036	1.0036	1.0036	1.0037
24.0	1.0035	1.0036	1.0036	1.0037	1.0037	1.0038	1.0038
24.5	1.0037	1.0037	1.0038	1.0038	1.0039	1.0039	1.0039

Z values in microliters per milligram

6 Accessories and Consumables

6.1 Accessories

General	Part No.
EVOLVE multipurpose tool (for calibration, O-ring removal and plunger spring exchange)	3200
Wall mount for handheld pipettes	3205
EVOLVE pipette shelf hook, pack of 1	3210
EVOLVE pipette shelf hook, pack of 5	3211
Short linear stand, holds up to 6 EVOLVE pipettes	3214
Linear stand, holds up to 12 EVOVE pipettes	3215

POPTOP base for reuse with ECO racks or GREEN CHOICE refills	Part No.
Small POPTOP base, for use with 12.5 µl, 125 µl and 300 µl GRIPTIPS	3250
Large POPTOP base, for use with 300 µl long and 1250 µl GRIPTIPS	3255

Color coded plunger caps (pack of 5)	Part No.
Black for use with any pipette	3220
Purple for use with 2 µl, 10 µl, 20 µl manual pipettes	3221
Yellow for use with 50 µl, 100 µl manual pipettes	3222
Green for use with 200 µl manual pipettes	3223
Blue for use with 1000 µl manual pipettes	3224
Orange for use with 5000 µl manual pipettes	3225

EVOLVE control spring assembly	Part No.
For single channel pipettes 2, 10, 20, 100, 200 and 1000 µl only	3230

6.2 Consumables

O-rings	Part No.
for 200/300 µl tip fittings, pack of 24	100-00027-50
for 1000/1250 µl tip fittings, pack of 24	100-00028-50
for 5000 µl tip fittings, pack of 10	100-00029-00

Grease for pipettes and O-rings	Part No.
Kluberalfa lube, for single channel pipettes 20 µl – 5000 µl	500-00182-00
Nye fluorocarbon gel 807, 5 g, for single channel pipettes 2 µl – 10 µl	100-00136-50

6.3 GRIPTIPS

INTEGRA offers a wide range of GRIPTIPS in the volume ranges from 12.5 µl – 5000 µl.



Visit the GRIPTIP Selector Guide (www.integra-biosciences.com/griptips) to find the correct GRIPTIPS and set a filter by available volumes, packaging and properties.

6.3.1 GRIPTIPS for handheld pipettes

EVOLVE pipettes are compatible with GRIPTIPS for handheld pipettes.

6.3.2 Package options

- **ECO Racks** (3xxx series): lightweight PET racks, environmentally friendly with 60% less plastic. They have a carbon footprint half the amount of standard racks. Most convenient experience when paired with the reusable POPTOP Base.
- **GREEN CHOICE** (44xx series): environmentally friendly refills allowing the reuse of existing racks and thus reduces plastic waste.
- **Standard racks** (4xxx series): refillable with GREEN CHOICE inserts.
- **Bulk packs**: tips in a resealable bag for hand loading.

6.3.3 GRIPTIP properties

According to our cleanroom standards, all GRIPTIPS (non-sterile, pre-sterilized and sterile) comply with our VIAPURE claims. This states that all product are RNase, DNase, Endotoxin and Pyrogenic free.

- **Sterile/pre-sterilized** products are gamma irradiated within the minimum and maximum dosage range specified for INTEGRA sterile products. Racks are individually vacuum sealed in a bag and are considered sterile until opened. Pre-sterilized ECO Racks are individually latched and sealed with a heat shrink band. The entire case of 5 pre-sterilized GREEN CHOICE inserts are sealed.
- **Non-sterile** items are manufactured in the same cleanroom and packed in a carton case.
- **Long**: longer design allows easy access into deep laboratory vessels
- **Short**: shorter design allows easy access in 1536 well plates or improves ergonomics
- **Wide bore**: large opening at the tip end, reduces shear forces
- **Low retention**: low liquid retention, for liquids with low surface tension

Imprint

© 2024 INTEGRA Biosciences AG

All rights to this documentation are reserved. In particular the rights of reproduction, processing, translation and the form of presentation lie with INTEGRA Biosciences AG. Neither the complete documentation nor parts thereof may be reproduced in any way, or stored and processed using electronic media or distributed in any other way without the written consent of INTEGRA Biosciences AG.

Every effort has been made to provide complete and accurate information in this manual. Although this manual should contain a specifically labeled warranty notice for the product, INTEGRA Biosciences AG makes no representations or warranties with respect to the contents of this manual and reserves the right to change this manual without notice if and when improvements are made.

INTEGRA Biosciences AG shall not be liable for any loss, damage, repair costs, incidental or consequential damages of any kind, whether based on express or implied warranty, contract, omission or strict liability, arising in connection with the design, development, installation or use of the products.

INTEGRA Biosciences AG aims to provide reliable and accurate data and documentation. If you find a discrepancy, we would be grateful for your assistance and ask you for email us at info@integra-biosciences.com.

This operating instruction manual has part number 900-00010-00, the version is V07. It applies to EVOLVE manual pipettes as of serial number 2116000 or higher of until a newer revision is released.

EVOLVE and GRIPTIPS are trademarks of INTEGRA Holding, Switzerland.

Manufacturer and customer service

Your local INTEGRA Biosciences representative, further information, and operating instructions in other languages can be found at www.integra-biosciences.com or are available on request info@integra-biosciences.com.

Manufacturer

INTEGRA Biosciences AG

Tardisstrasse 201
CH-7205 Zizers, **Switzerland**
T +41 81 286 95 30
info-ch@integra-biosciences.com

INTEGRA Biosciences Corp.

22 Friars Drive
Hudson, NH 03051, **USA**
T +1 603 578 5800
info-us@integra-biosciences.com

Direct sales country

Integra Biosciences PTY Ltd

Unit 55, 193-203 South Pine Road
Brendale QLD 4500, **Australia**
T +617 3497 5800
info-au@integra-biosciences.com

INTEGRA Biosciences (Shanghai) Co., Ltd.

Room 1110, No. 515 Huanke Road
Shanghai 201315, **China**
T +86 21 5844 7203
info-cn@integra-biosciences.com

INTEGRA Biosciences Nordic ApS

Vallensbækvej 22A 3TV
Brøndby 2605, **Denmark**
T +45 3173 5373
info-nordic@integra-biosciences.com

INTEGRA Biosciences SAS

8 avenue du Fief
95310 Saint Ouen l'Aumône, **France**
T +33 1 34 30 76 76
info-fr@integra-biosciences.com

INTEGRA Biosciences Deutschland GmbH

An der Amtmannsmühle 1
35444 Biebertal, **Germany**
T +49 6409 81 999 15
info-de@integra-biosciences.com

INTEGRA Biosciences KK

Higashikanda 1-5-6, Chiyoda-ku
Tokyo, 101-0031, **Japan**
T +813 5962 4936
info-jp@integra-biosciences.com

INTEGRA Biosciences Benelux BV

Smederijstraat 2
4814 DB Breda, **Netherlands**
T +31 630 609 866
info-benelux@integra-biosciences.com

INTEGRA Biosciences Ltd

2 Rivermead Business Park
Thatcham, Berks, RG19 4EP, **United Kingdom**
T +44 1635 797 00
info-uk@integra-biosciences.com
